

LUXEMBOURG – SATURDAY 18 MAY 2019

A STARTER FOR TEN

Roy Goldring Graded and Social Dances 3

Jig 5 x 32 bars 5 Couple Repeat 5 Couple Set Longwise Set

1-8 1s cross by the right; 1s cast 2 places (2s+3s step up on bars 3-4); 3s1M 1L4s right hands across;

9-16 1L cross up, 1M down, into half figures of 8 across; 3s1M 1L4s left hands across;

17-20 2M1L 1M5L turn by the right, 1s finishing by passing by the right;

21-24 2L1M 1L5M turn by the left, finishing 2s3s1s4s5s on own sides;

25-28 1s advance and cast to 5th place;

29-32 2s 3s 4s 5s 1s turn both hands (skip change).

<https://www.scottish-country-dancing-dictionary.com/video/starter-for-ten.html>

A STARTER FOR TEN			5x32 J	
X_R 	3 ① ① 4 RA		3 ① ① 4 LA	
② ① ① ⑤ T_R 	② ① ① ⑤ T_L			2 3 4 5 1 T_B Skip change

Roy Goldring, Graded & Social Dances 3

5C/5C longwise set.

TRIP TO TIMBER RIDGE (R8X32) 3C (4C set) Linda Henderson Heart of San Francisco and RSCDS Book 52

- 1- 8 1s turn RH, cast (2s step up on bars 3-4) then 1L+2s and 1M+3s dance RH across. 1s end facing 1st corners
- 9-16 1s dance Corner Pass&Turn with 1st corners, pass RSh and repeat with 2nd corners. 1s pull back RSh to end BtoB in centre facing opposite sides
- 17-24 2s+1s+3s dance Double Triangles. Bars 23-24 1s petronella turn to 2nd place own sides
- 25-32 2s+1s+3s circle 6H round and back

<https://www.scottish-country-dancing-dictionary.com/video/trip-to-timber-ridge.html>

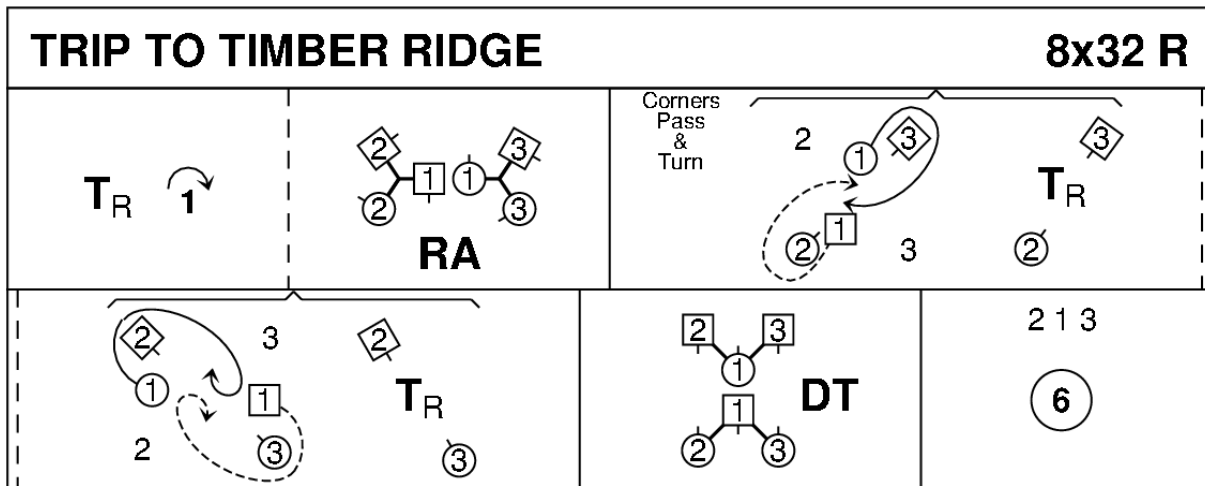

Linda Henderson, 2010, RSCDS Book 52.12

3C/4C longwise set.

HELLO-GOODBYE (S8x32) 3C (4C set) Chris Ronald RSCDS Book 51

- 1- 8 1s set, cross RH, cast (2s step up on bars 5-6) and turn $\frac{3}{4}$ RH to face opposite sides (2s step up on 5-6)
- 9-16 1M+2s also 1L+3s dance LH across, 1s pass LSh to dance RH across with other couple. 1s end BtoB in middle facing 1st corners
- 17-24 1s dance 'Hello-Goodbye' setting, clap and petronella turn to 2nd place own side
- 25-32 2s+1s+3s circle 6H round and back

<https://www.scottish-country-dancing-dictionary.com/video/hello-goodbye.html>

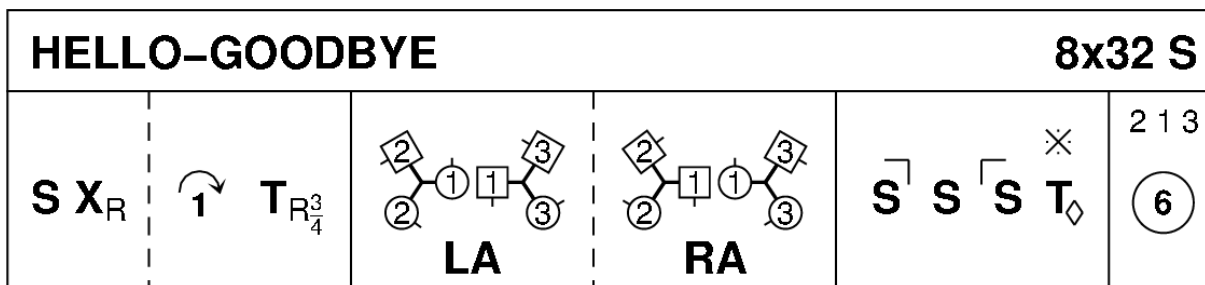

Chris Ronald, 2012, RSCDS Book 51

3C/4C longwise set.

BERWICK JOHNNIE (J8x32) 3C (4C set) Book of Graded SCDs

1- 8 1s+2s set, dance ½ RH across, set and dance ½ LH across

9-16 1s lead down the middle and back to top

17-24 1s+2s dance Allemande 1s end facing 1st corners

25-32 1s turn 1st corners RH, partner LH, 2nd corners RH and partner LH to 2nd places

<https://www.scottish-country-dancing-dictionary.com/video/berwick-johnnie.html>

BERWICK JOHNNIE			8x32 J
$\overbrace{\quad\quad}^{1\ 2}$ S RA S LA	\longleftrightarrow	1 2 A	

RSCDS Graded Book 1.14

3C/4C longwise set.

THE DANCING BEES (R8x32) 3C (4C set) Roy Goldring 24 G and S Dances

1- 8 1s lead down the middle and back to face 2L in prom hold ((2s step up on bars 3-4)

9-16 1s dance reel of 3 across with 2s (giving RSh to 2L)

17-24 1s dance reel of 3 across with 3s (LSh to 3L) ending in the middle (Man facing down and Lady facing up to partner)

25-32 1s set in middle, petronella to 2nd place own sides and 2s+1s+3s turn RH (4 bars)

<https://www.scottish-country-dancing-dictionary.com/video/dancing-bees.html>

THE DANCING BEES				8x32 R
\longleftrightarrow	2 	3 	2 3 	2 1 3 T_R

Roy Goldring, 24 Graded & Social Dances

3C/4C longwise set.

MONTPARNASSE (S4x32) 4C set Ann Dix Reel Friends 3

- 1- 8 1s and 4s set and cross RH, cast in 1 place (2s and 3s step down/up on bars 5-6) and dance LH across ½ way
 9-16 All dance RSh reels of 4 on sides and end facing up/down
 17-24 All set to facing person sides and turn 2H, 2s+4s also 1s+3s circle 4H round to left
 25-32 2s+4s also 1s+3s dance Diamond Poussette

<https://www.scottish-country-dancing-dictionary.com/video/montparnasse.html>

MONTPARNASSE				4x32 S		
1 4 S X_R	1x 4x 1 1 LA	2 4 1 3 	2-4 1-3 S T_B 2-4 1-3	2 4 1 3 4 P	2 4 1 3 P	

Ann Dix, 2003, Reel Friends 3

4C/4C longwise set.

PEAT FIRE FLAME (R8x40) 3C (4C set) John Drewry Bon Accord Book

- 1- 8 1s cast 1 place (2s step up on bars 1-2) and dance ½ Fig of 8 round 2s and turn ¾ LH to face 1st corners
 9-16 1s turn 1st corner RH, pass partner RSh and turn 2nd corner LH pass partner LSh to face 1st corners
 17-24 1s dance ½ diagonal reel of 4 with 1st corners and ½ diagonal reel with 2nd corners to end in centre BtoB facing 3rd corners (1st corner persons)
 25-32 1s set to 3rd corners and dance round one another clockwise to 4th corners, set and dance clockwise to face out on opposite sides
 33-40 1s dance out and cast round 1st corner into centre while 2s and 3s dance ½ R&L, 2s+1s+3s turn RH. 213

<https://www.scottish-country-dancing-dictionary.com/video/peat-fire-flame.html>

THE PEAT FIRE FLAME			8x40 R	
1 	T_L^{3/4} 	T_R 	T_L 	
	S 		S 	3x 2x RL
				ALL T_R

John Drewry, 1968, Bon Accord Book

3C/4C longwise set

THE BURNTISLAND JIG (J5x32) 5C set Bob Beattie Three Hands Across

1- 8 1s and 3s cross RH and cast 1 place (2s and 4s step up on bars 3-4), 1s and 3s dance down between couples below and cast up to end BtoB with partners facing out

9-16 1s and 3s dance Double Triangles with 2s+4s+5s and BtoB with partners facing opposite sides

17-24 1s and 3s turn 1st corners RH and pass partner RSh to face 2nd corners, 1s and 3s turn 2nd corners RH to end on opposite sides between corners and all set

25-32 2s+1s+4s+3s+5s Adv&Ret, 1s and 3s cross RH and cast 1 place

THE BURNTISLAND JIG				5x32 J	
1 3 X_R 1	1x 3x 1 N	2 1x 4 3x 5 DT	1 3 2 1x 4 3x 5 T_R S	ALL ↑↓	1x 3x X_R 1

Bob Beattie, 2011, Three Hands Across, RSCDS BHS Border

5C/5C longwise set.

SCOTT MEIKLE (R4x32) 4C set Alice McLean Laurieston Collection 1 and RSCDS Book 46

1- 8 1s cross RH and cast to 2nd place (2s step up on bars 3-4), 1s dance ½ Fig of 8 round 2s

9-16 1s+3s dance RH across, LH back

17-24 1L followed by 3L dance Tandem reel of 3 across with 2s (LSh to 2M) and 1s end 3rd place while 3M followed by 1M dance reel of 3 with 4s (LSh to 4L) and 3s end in 2nd place. 2314

25-32 1s+4s dance ½ R&L, turn partners RH 1½ times. 2341

<https://www.scottish-country-dancing-dictionary.com/video/scott-meikle.html>

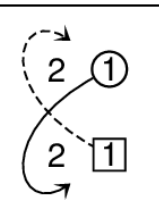
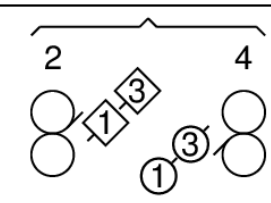
SCOTT MEIKLE				4x32 R	
X_R 1		1 3 RA LA		1 4 RL	4x 1x T_R 1½

Alice McLean, Laurieston Collection 1, RSCDS Book 46.3

4C/4C longwise set.

SANDS OF MORAR (S8x32) 3C (4C set) Barry Priddey RSCDS Book 45

1- 8 1s dance Fig of 8 round 2s giving hands when possible

9-16 1s dance reflection reels of 3 on own sides (1s dance down between 2s to begin)

17-24 1s turn 2H and dance down middle to 3rd place as 2s+3s continue reel and dance down behind 1s, all set and 1s followed by 2s+3s cast up to original places

25-32 1s+2s dance the Tourbillon:-

' 1s and 2s turn partners 2H ½ way, 1M and 2L lead partners on 1 place clockwise to end 1s on Ladies' side and 2s on Men's side, 1s set to 2s

' 1s and 2s ½ turn partners 2H, 1L and 2M lead partners on 1 place to end 2s in 1st place and 1s in 2nd place and 2s+1s cross RH to own sides

<https://www.scottish-country-dancing-dictionary.com/video/sands-of-morar.html>

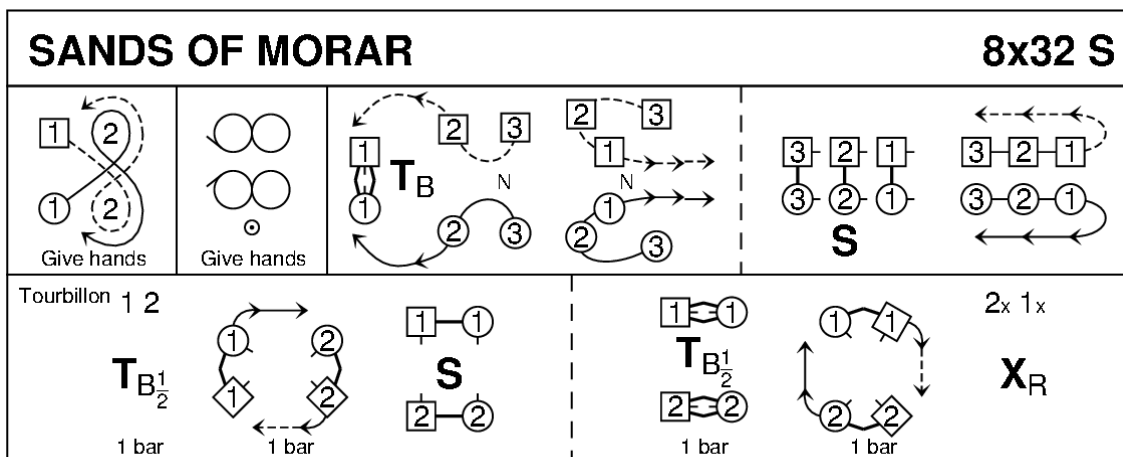

Barry Priddey, 1983, Glasgow Diamond Jubilee & RSCDS Book 45.6

3C/4C longwise set.

GAELFORCE WIND (J8x32) 3C (4C set) Derek Haynes Carnforth Collection 3

1- 8 1s set, cross RH, 1s+2s Set&Link (Ladies face out)

9-16 2s+1s Men's Chain

17-24 1s ½ Figs of 8 (L round 2s and M round 3s), 2s+1s+3s turn RH and open into

25-32 2s+1s+3s circle 6H round and back

<https://www.scottish-country-dancing-dictionary.com/video/gaelforce-wind.html>

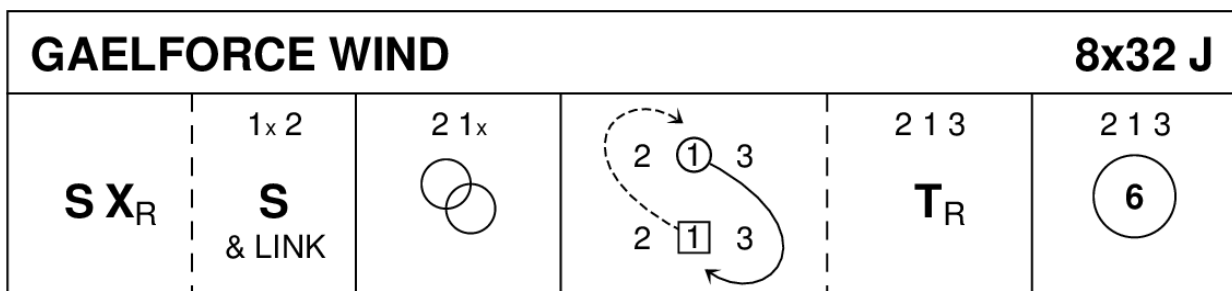

Derek Haynes, 1996, Carnforth Collection 3, RSCDS Graded Book 3.12

3C/4C longwise set.

CITY OF STIRLING REEL (R8x32) 3C (4C set) Roy Goldring

- 1- 8 1s+2s+3s dance Snowball Grand Chain (1s+2s change places on sides to start). (3)(1)(2)
- 9-16 1s cross (pass RSh) and ½ turn RH person in 3rd corner, 1s followed by corners change places (diag) passing LSh and 1s cast to 2nd place (opposite sides) as corners end in original places
- 17-24 1s cross (pass LSh) and ½ turn LH person in 4th corner, 1s followed by corners change places (diag) passing RSh and 1s cast to 2nd place (opposite sides) as corners end in original places. 2(1)3
- 25-32 All turn RH (4 bars) and 1s dance ½ Figs of 8 (Lady up and Man down)

<https://www.scottish-country-dancing-dictionary.com/video/city-of-stirling-reel.html>

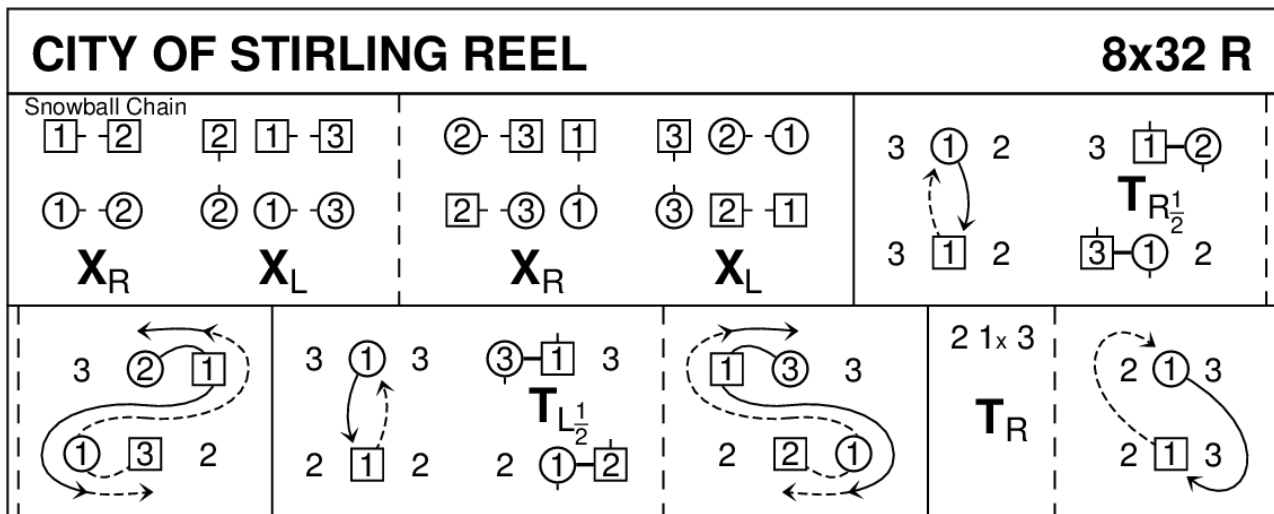

Roy Goldring, 2005, Auld Friends Meet

3C/4C longwise set.

TRIPLE HAPPINESS (S3x32) 3C Yoshiki Oyama RSCDS Book 52

1- 8 1s Adv&Ret (1 step each) touching hands, 1s ½ turn LH, cross down between 2s and 3s, cast up to place

9-16 1s+2s dance the Knot. 1s end facing 1st corners

17-24 Corners Pass&Turn with 1st corners, Repeat with 2nd corner and 1s pass RSh into 2nd place own sides (corners turn 2H in centre) 213

25-32 All chase clockwise ½ round to opposite sides, all ½ turn 2H, pull back RSh and dance out to own sides. 312

<https://www.scottish-country-dancing-dictionary.com/video/triple-happiness.html>

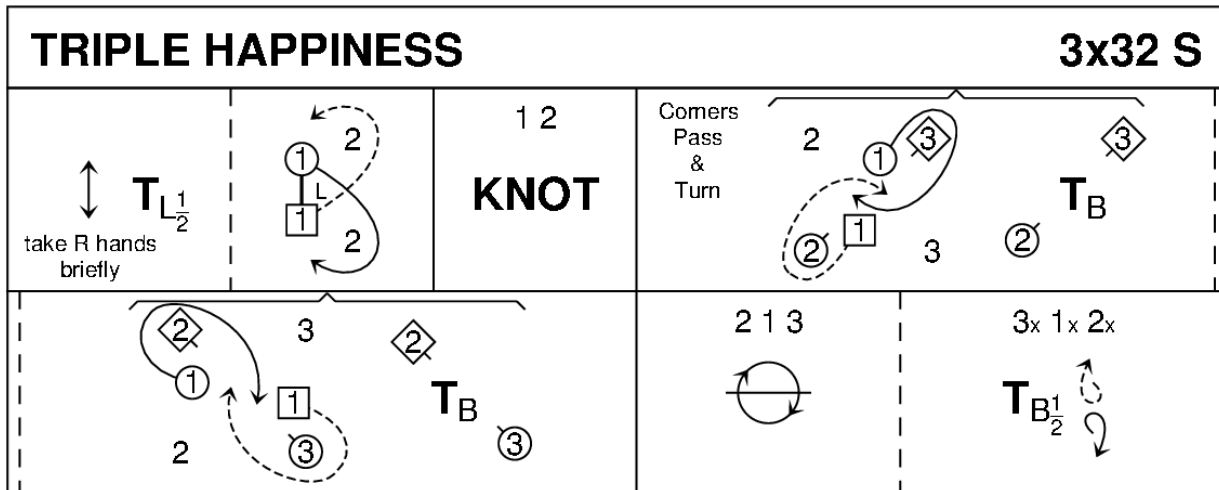

Yoshiki Oyama, 2016, RSCDS Book 52.10

3C/3C longwise set.

LIQUID ASSETS (J8x32) 3C (4C set) John Drewry Stoneywood Collection 2

1- 8 1s cross down to dance reflection reels of 3 on opposite sides 1s ending at top on opposite sides facing in and 2s face out

9-16 1s turn 2s 1½ times with nearer hands, 1s turn 3s 1½ times with other hand

17-24 1s cross up to dance reels of 3 on own side, at end 3s face out

25-32 1s turn 3s 1½ times with nearer hands, 1s dance up to top and cast to 2nd places

<https://www.scottish-country-dancing-dictionary.com/video/liquid-assets.html>

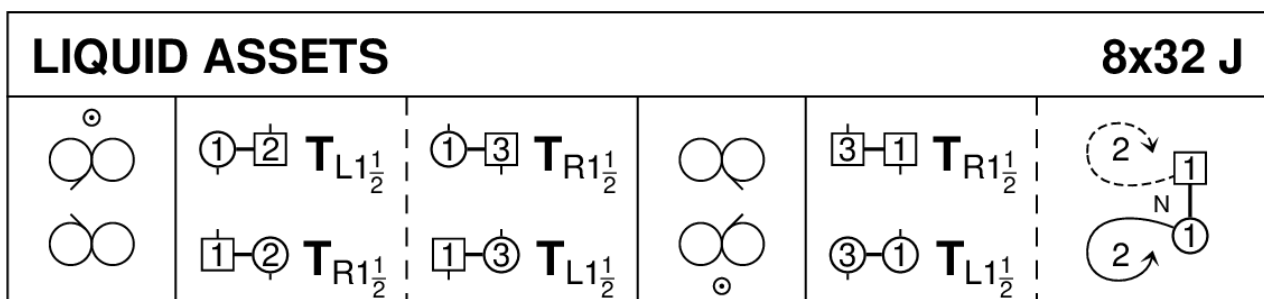

John Drewry, 2002, Stoneywood Collection 2

3C/4C longwise set.

MARKET SQUARE (M-(S64+R64)) Sq.Set Dorothy Bell Starters Collection*Strathspey*

1- 8 All circle 8H round and back

9-16 Ladies dance RH across and turn partner RH

17-24 Men dance LH across and turn partner LH into prom hold

25-32 All Promenade clockwise once round

33-40 1s+3s in prom hold pass RSh and dance round to right behind 4s/2s back to places

41-48 2s+4s repeat

49-56 1s+3s Adv&Ret, 2s+4s Adv&Ret

57-64 Ladies with partners on their left dance RH across once round

Reel

All clap and repeat

<https://www.scottish-country-dancing-dictionary.com/video/market-square.html>**REEL OF THE 51ST DIVISION (R8x32) 3C (4C set) Atkinson RSCDS Book 13**







1- 8 1s Set&Cast below 3s (2s step up on bars 3-4), lead up to face 1st corners

9-16 1s set and turn 1st corners RH to balance in diagonal line, set and 1s turn LH to face 2nd corners

17-24 1s set and turn 2nd corners RH to Balance-in-Line, set and 1s turn LH to 2nd place own sides

25-32 2s+1s+3s circle 6H round and back

<https://www.scottish-country-dancing-dictionary.com/video/reel-of-the-51st-division.html>

THE REEL OF THE 51st DIVISION			8x32 R
S 	S  T_R B  T_L^{1 1/4}	S  T_R B  T_L	2 1 3 

Jimmy Atkinson & Peter Oliver, 1940, RSCDS Book 13.10

3C/4C longwise set.